

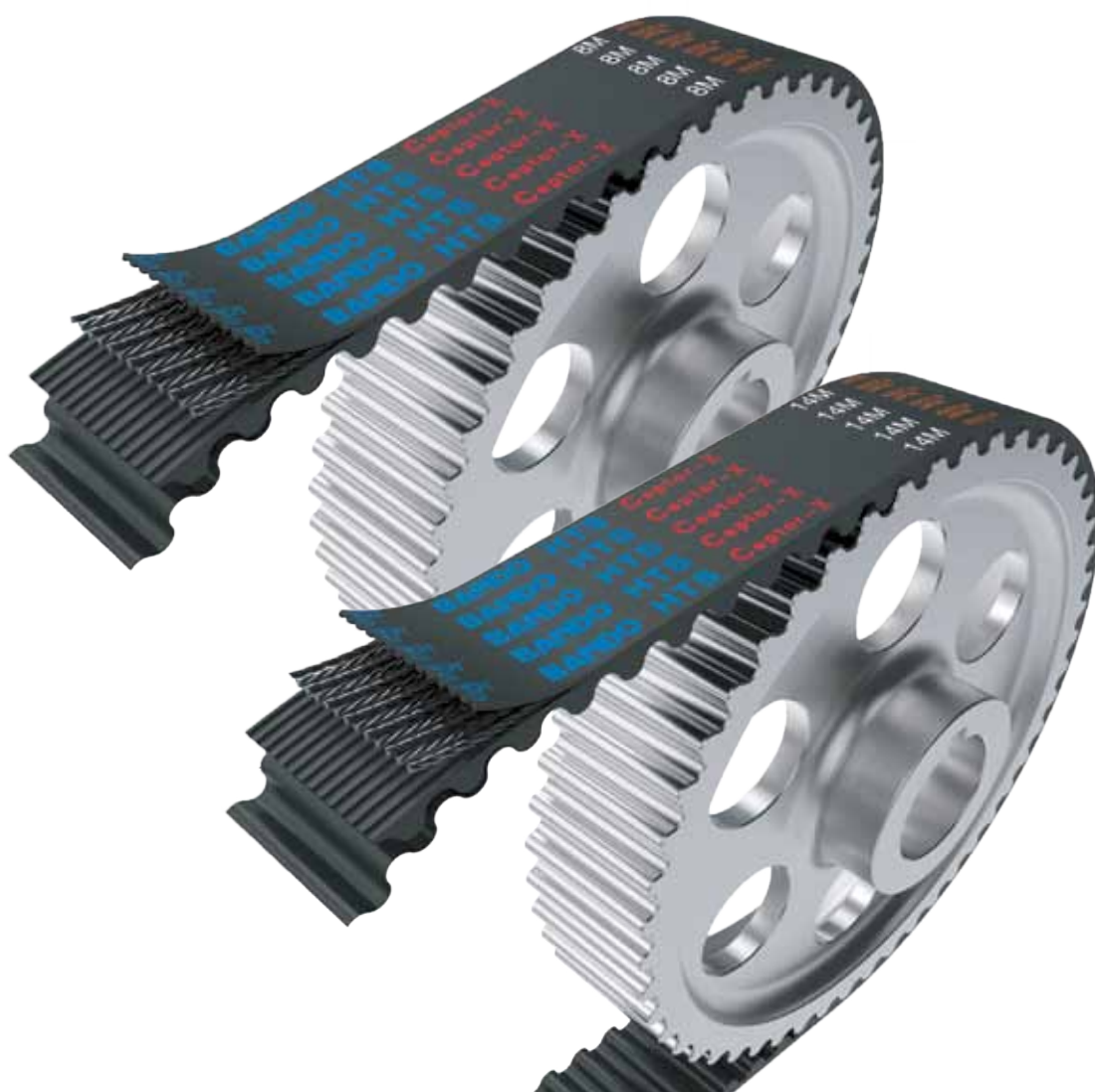

Ceptor®-X HTS

High torque CARBON CORD
HTS synchronous belt

Ceptor®-X HTS



FEATURES

- Increased transmission capacity provides high-performance in a compact space

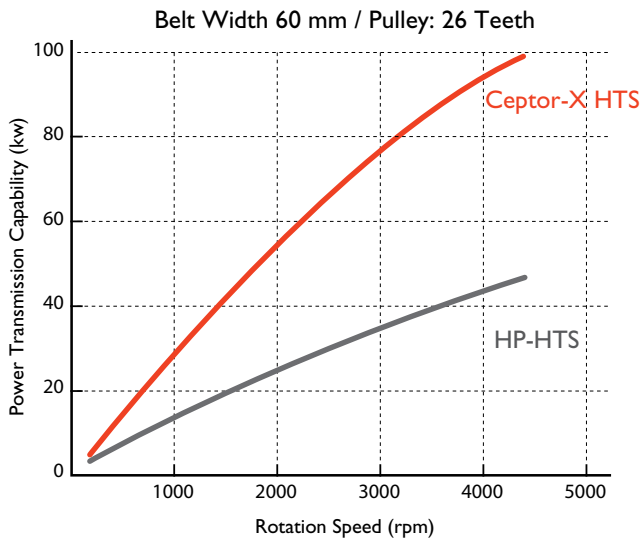

Reduced Belt Width with Ceptor-X

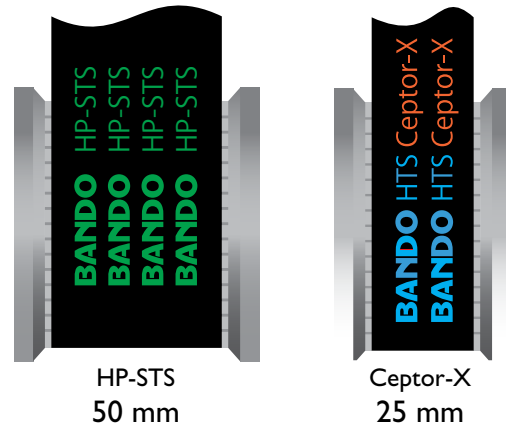

- Longer-lasting belt life decreases maintenance and replacement costs.
- High transmission capacity makes it possible to use even narrower belts and pulleys

BELT STRUCTURE

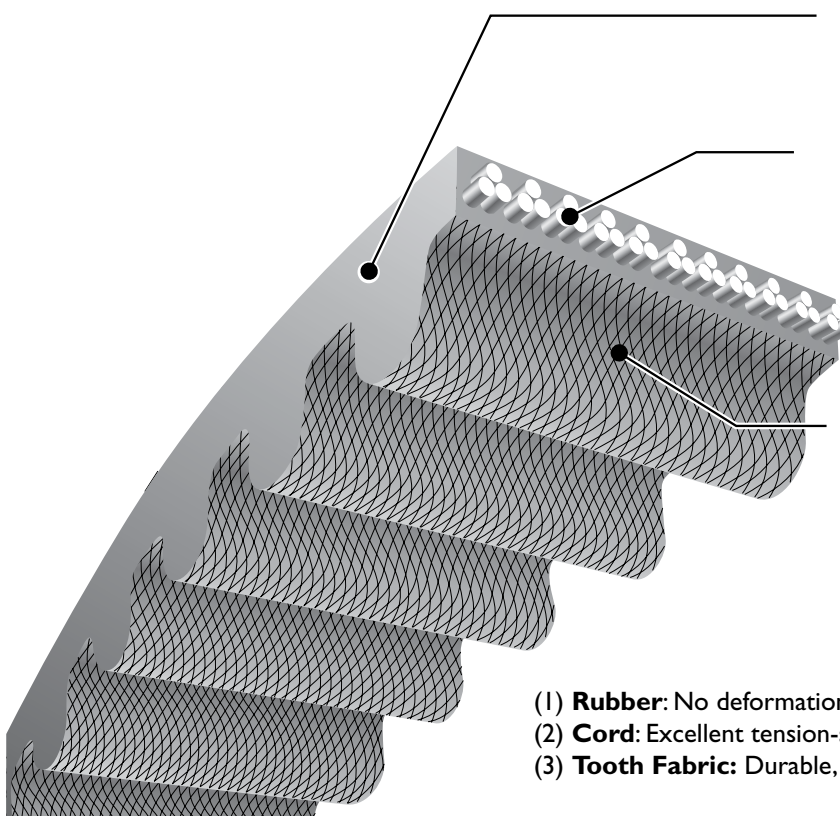

- 1. Tooth Rubber**
HNBR
- 2. Tension Member**
Carbon
- 3. Tooth Fabric**
Special coated Nylon Fabric

- (1) Rubber:** No deformation of teeth - hard flexible synthetic rubber
- (2) Cord:** Excellent tension-sustaining, high-strength carbon cord
- (3) Tooth Fabric:** Durable, anti-wear canvas prevents tooth shear

PERFORMANCE

- **Layout flexibility:** can use backside idler pulley
- **Noise:** quieter than “polyurethane” synchronous belt

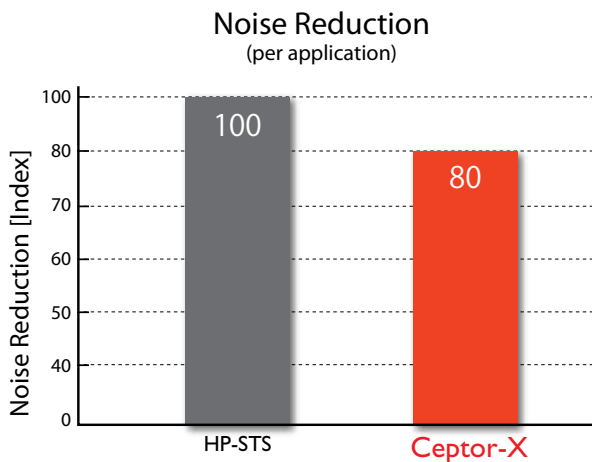

Low noise results from narrower belt width (approximately 20%) compared to HP-STC.

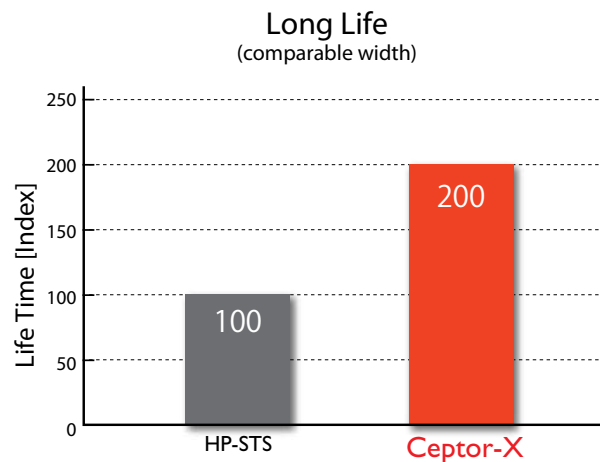

Due to strong carbon cords and wear-resistant canvas surface, there is minimal belt stretch and tooth wear, increasing durability and service life of the belt.

Runs on primary and 2nd generation “H” pulleys.



Designed for 2nd Generation H-Profiles.



Suitable for H-Profiles



Product Line-Up

HTS Ceptor® X 8M

Part Number Example

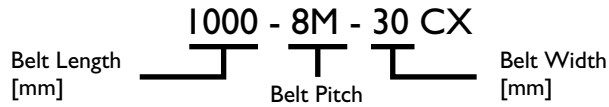

Description	Pitch Length (mm)	No. of Teeth
384-8MC-X	384	48
424-8MC-X	424	53
480-8MC-X	480	60
560-8MC-X	560	70
600-8MC-X	600	75
624-8MC-X	624	78
640-8MC-X	640	80
656-8MC-X	656	82
680-8MC-X	680	85
720-8MC-X	720	90
760-8MC-X	760	95
800-8MC-X	800	100
840-8MC-X	840	105
856-8MC-X	856	107
880-8MC-X	880	110
896-8MC-X	896	112
920-8MC-X	920	115
960-8MC-X	960	120
1000-8MC-X	1000	125
1040-8MC-X	1040	130

Description	Pitch Length (mm)	No. of Teeth
1056-8MC-X	1056	132
1064-8MC-X	1064	133
1080-8MC-X	1080	135
1120-8MC-X	1120	140
1152-8MC-X	1152	144
1160-8MC-X	1160	145
1184-8MC-X	1184	148
1192-8MC-X	1192	149
1200-8MC-X	1200	150
1224-8MC-X	1224	153
1248-8MC-X	1248	156
1264-8MC-X	1264	158
1280-8MC-X	1280	160
1304-8MC-X	1304	163
1360-8MC-X	1360	170
1392-8MC-X	1392	174
1400-8MC-X	1400	175
1424-8MC-X	1424	178
1440-8MC-X	1440	180
1480-8MC-X	1480	185

Description	Pitch Length (mm)	No. of Teeth
1512-8MC-X	1512	189
1520-8MC-X	1520	190
1584-8MC-X	1584	198
1600-8MC-X	1600	200
1680-8MC-X	1680	210
1728-8MC-X	1728	216
1760-8MC-X	1760	220
1800-8MC-X	1800	225
1904-8MC-X	1904	238
2000-8MC-X	2000	250

HTS Ceptor® X 14M

Part Number Example



Description	Pitch Length (mm)	No. of Teeth
966-14MC-X	966	69
1092-14MC-X	1092	78
1190-14MC-X	1190	85
1344-14MC-X	1344	96
1400-14MC-X	1400	100
1456-14MC-X	1456	104
1540-14MC-X	1540	110
1610-14MC-X	1610	115
1680-14MC-X	1680	120
1778-14MC-X	1778	127
1890-14MC-X	1890	135

Standard Width Sizes [mm]								
	20	30	40	50	55	85	115	170
8M								
14M								

Available Sizes

* Please note that this catalogue is reserved to changes. All data in this publication have been compiled and checked with utmost diligence, nevertheless errors and mistakes cannot be totally excluded. Do not duplicate or copy any part or contents without the permission of Bando Europe GmbH.

Authorised distributor:



TYMA CZ, s.r.o.

Na Pískách 731, CZ - 400 04 Trmice
 Phone: +420 475 655 010, Email: info@tyma.cz
www.tyma.cz